

EDAS® ETHERNET DATA ACQUISITION SYSTEMS

REMOTE I/O OVER ETHERNET
REAL-TIME, INTERACTIVE ACCESS TO PLANTWIDE DATA

- High-Accuracy 16-Bit Multifunction I/O EDAS
- Serial-to-Ethernet Converter
- Digital I/O
- Industrial Enclosure
- COM Port Drivers

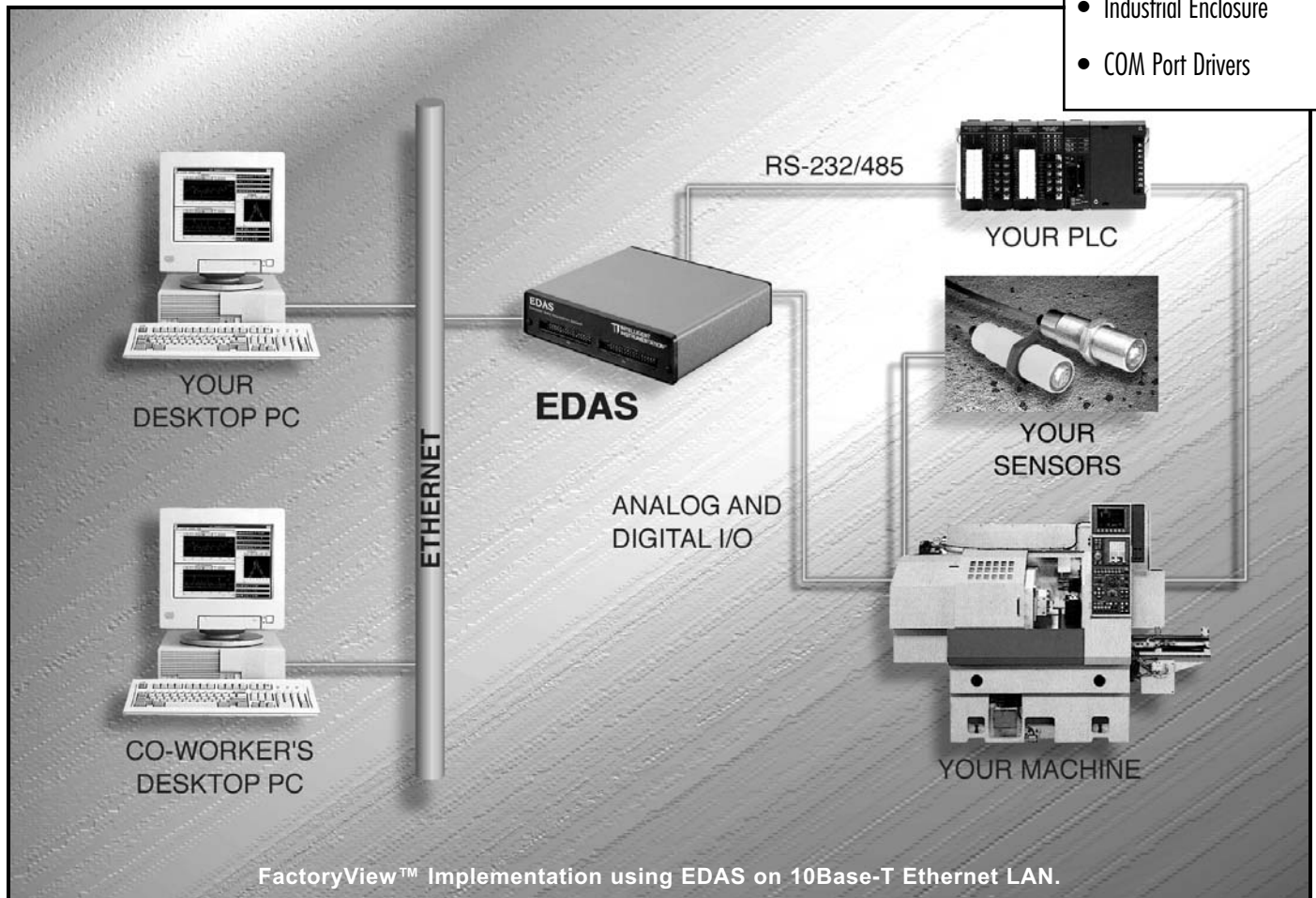

TYPICAL APPLICATIONS

- ▲ Machine Monitoring and Control
- ▲ Process Monitoring
- ▲ Environmental Monitoring and Control
- ▲ Remote Data Acquisition
- ▲ Test & Measurement

BENEFITS

- ▲ Provides management visibility of plant operations and productivity
- ▲ Utilizes existing Ethernet wiring—no need to install proprietary I/O network
- ▲ Open systems environment provides easy interface to plantwide systems and software
- ▲ Low cost per I/O point

EDAS® Ethernet Data Acquisition Systems provide you with real-time, interactive I/O, allowing you to visualize your work environment over a network. They utilize the open systems environment of Ethernet to integrate your acquired data with your company or enterprise network, making the data available for use by other networked resources, PC's, workstations and/or databases. EDAS units communicate over any Ethernet or Internet network using built-in industry-standard TCP/IP protocol, providing a non-proprietary interface to virtually any host.

EDAS systems are available in Digital I/O, Multifunction I/O and Serial I/O models, so you can choose the functions you need for your application.

TABLE OF CONTENTS

SECTION 1 ETHERNET DATA ACQUISITION SYSTEMS

Digital EDAS - Digital I/O	3-5
Industrial Hardened Digital EDAS - Digital I/O	6
Multifunction EDAS - Analog and Digital I/O	7-10
Serial EDAS - Serial-to-Ethernet Converter	11-12

SECTION 2 SOFTWARE

iFactory Monitor	13-15
Net Link Drivers	16
Accessories	16

SECTION 3 TERMINATION & SIGNAL CONDITIONING

Low-Cost Termination Panels	17
Din-Rail Mount Termination Panels	17
3U Termination Panels & Enclosures	17-18
General-Purpose Termination Panels & Enclosures	18-19
Signal Conditioning / Isolator Modules	19

SECTION 4 ORDERING GUIDE



Digital EDAS



Multifunction EDAS



Serial EDAS

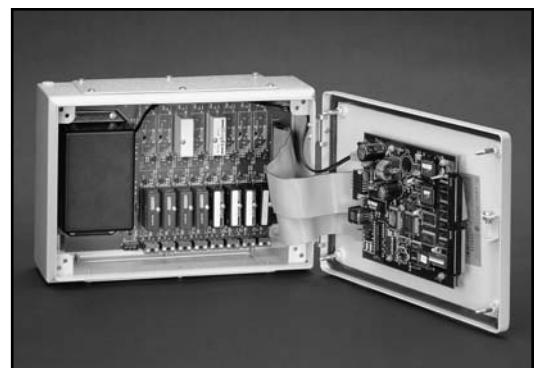

Industrial Enclosure EDAS

KEY FEATURES

- ▲ Compact, efficient design
- ▲ Communicates using 10Base-T and embedded TCP/IP protocol
- ▲ Analog I/O—Measure voltage, current, pressure, flow, resistance, strain, temperature
- ▲ Digital I/O—Detect states, latch state changes, count events; set output states, generate variable pulse-width or delayed outputs and square waves
- ▲ Serial RS-232/485 Data—Monitor and control instruments, scales, gauges, smart sensors, machines and auto ID terminals
- ▲ Both synchronous and asynchronous communications supported

REAL-WORLD APPLICATIONS

AMP, Incorporated - Factory Machine Monitoring

AMP, Inc. is implementing a corporate-wide machine monitoring system based on EDAS Ethernet data acquisition systems. The system monitors each of hundreds of custom assembly and molding machines used in the process of manufacturing connector products, monitoring production counts and machine utilization and reporting alarm conditions.

This monitoring system is based on the EDAS-1001E Digital I/O system. The EDAS units operate side by side with PLC's which perform the discrete control operations necessary to run the machines. However, the advanced counting, reporting and alarm features of the EDAS made it an easy choice for handling the monitoring functions. EDAS units report data to USDATA FactoryLink SCADA nodes under the UNIX operating system. Data is in turn reported to Amp's MES system, where it is used by local and corporate management to determine machine and plant efficiency as well as for production and maintenance scheduling. The system allows AMP to minimize manufacturing downtime and increase productivity.

Hughes Information Technology Systems - Satellite Telemetry Switching

Mid-Atlantic RF Systems, a Systems Integrator in Forest Hill, MD, developed a satellite telemetry switching system which employs an embedded EDAS Ethernet data acquisition system. Hughes Information Technology Systems employs these systems, called Switch Mainframe Assemblies (SMA's), to switch satellite telemetry communications from one base station, or ITCU, to another in the event of a base station failure. The SMA allows Hughes to minimize communications downtime with the satellites.

The system is a relay matrix which connects satellite command signals to a selected uplink and satellite telemetry downlink signals to a selected ITCU. In the event of a faulted on-line ITCU, the SMA switches in a hot back-up (redundant) ITCU. All switching is performed by TTL logic, while the EDAS system provides the communications link between the SMA and a host computer where commands are issued.

The Tech Museum Of Innovation - Exhibit Monitoring/Traffic Optimization

In addition to being on display as an example of modern manufacturing automation, EDAS units are used throughout this impressive museum of modern high-tech innovations in San Jose, CA, to monitor and control the exhibits. At each exhibit, the EDAS system coordinates lighting and any number of complex mechanical processes in response to approaching or departing visitor traffic.

New Mexico Technology Group (NewTec) - Facility Monitoring

Multifunction EDAS systems are being employed to monitor and control environmental conditions in research facilities at White Sands Missile Range in New Mexico. The EDAS system monitors and optimizes room temperatures and reports any leakage (alarm) conditions of cooling systems.

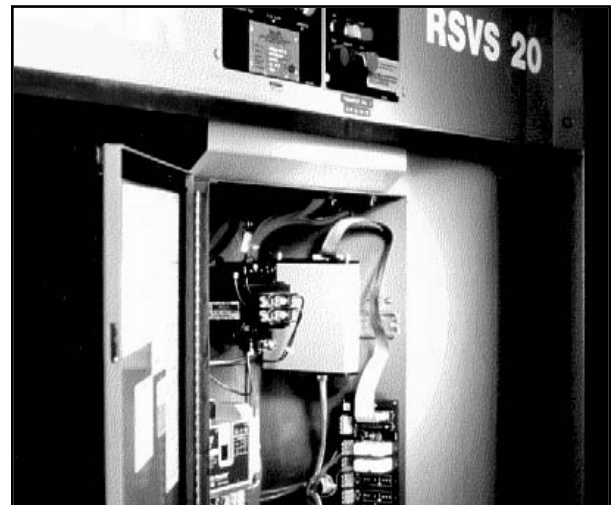

EDAS

Morgan Construction - Manufacturing

A multifunction EDAS unit forms part of an on-line vibration analysis system used to monitor vibration levels in machinery supplied to steel rolling mills. The EDAS reports data from accelerometers situated throughout the equipment.

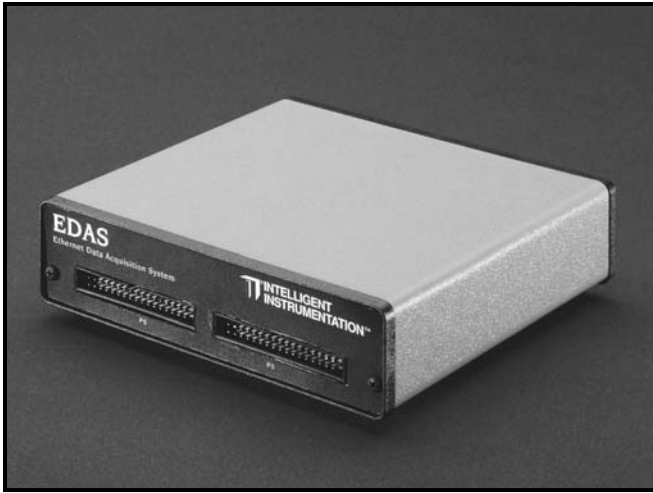

TYPICAL APPLICATIONS

- ▲ Machine Monitoring and Control
- ▲ Production/Cycle Counting
- ▲ Remote Data Acquisition

KEY FEATURES/BENEFITS

- ▲ 32 Programmable Digital I/O Channels
- ▲ Inputs programable to read digital signal status, change-of-state and to perform event counting
- ▲ Outputs can be programmed for normal (on/off), delayed, and variable delay/pulse-width modes
- ▲ Two 16-bit counter channels perform frequency measurement, high-speed event counting to 250 kHz
- ▲ Retain state and count information during loss of power
- ▲ One RS-232 port monitors and controls instruments, gauges, smart sensors, machines and terminals
- ▲ One RS-485 port monitors and controls instruments, smart sensors and machines
- ▲ Synchronous and asynchronous client/server communications
- ▲ Net Link drivers for Windows and UNIX available with complete documentation
- ▲ COM Port Drivers for Windows

EDAS-1001E SERIES

DIGITAL I/O ETHERNET DATA ACQUISITION SYSTEM

DESCRIPTION

The EDAS-1001E Series Digital I/O Ethernet Data Acquisition System is a low-cost member of a new family of products that provide remote I/O capabilities over Ethernet LANs and the Internet.

Digital I/O

Each EDAS-1001E provides 32 digital I/O channels, programmable in four byte-wide (8-bit) sections, or ports. Each digital port is TTL-level compatible and can be independently programmed for input or output. Through local signal processing, various digital input/output functions are supported. Inputs can be used to read the current status of digital signals, detect signal state-changes (latch a state), and count events up to 250Hz. Outputs can operate in simple on/off fashion, or can be programmed for specific delay times and on/off times for control and timing applications. In addition, eight of the digital output channels can be individually configured for predetermined output states at power-up. All inputs and outputs are protected from damage under power on and power off conditions.

High-Speed Counters

Two 16-bit high-speed programmable counters capable of counting TTL level signals up to 250kHz are also provided. These counters also perform direct frequency measurement. High-speed counter inputs are made available by multiplexing them with digital input lines.

Serial I/O

EDAS systems also feature serial I/O capabilities. An on-board RS-232 port can be used for both configuration and I/O applications. When the RS-232 port is in "Configuration Mode", any terminal device or computer with an RS-232 port can be used to program the unit's IP address, subnet mask and gateway parameters. With the port in "Command Mode", EDAS units can monitor and control almost any device with RS-232 connectivity, including instruments, scales, gauges, smart sensors, machines and terminals.

EDAS systems which feature RS-485 I/O capabilities are also available. In addition to analog, digital and RS-232 I/O capabilities, these units monitor and control any number of instruments, sensors, and machines with RS-485 connectivity.

Data Retention

The EDAS-1001E protects your data in the event of a power outage. After power is lost, the unit will retain state and count values on each channel for up to five days.

Operation

EDAS units act as application servers, providing I/O functions to clients on the network. They operate in both synchronous and asynchronous mode. In synchronous mode, a client polls the unit for digital input values and counter data, or to set output values. Asynchronous mode allows the unit to send data based on change-of-state or alarm conditions.

Termination Signal Conditioning

The EDAS-1001E interfaces to real world signals through two 34-pin connectors, giving you access to a wide variety of termination products and signal conditioning options. Refer to the Termination and Signal Conditioning Products for EDAS Section.

OEM Version

OEM Versions of EDAS systems are available to those who wish to incorporate this innovative design into a larger system. These "board-only" versions come without the rugged external case, allowing the circuit board to be mounted in an enclosure of your choice.

Starter Kits

FactoryView Starter Kits contain everything you need to begin performing remote I/O with your EDAS system.

- ▲ 1 EDAS unit
- ▲ 1 termination panel
- ▲ 1 termination panel
- ▲ 1 DIN-rail mounting kit
- ▲ 1 power adapter
- ▲ Cabling

- ▲ COM Port Drivers for Windows
- ▲ Net Link Software Libraries for Windows
- ▲ SYSCHECK Diagnostic/Utility Software
- ▲ Complete documentation

EDAS-1001E-SK1 (Digital I/O) Kits include a 90-120VAC power adapter. For 230VAC power requirements, order the EDAS-1001E-SK2 Kit.

ORDERING INFORMATION

EDAS-1001E-1	Digital I/O EDAS
EDAS-1001G-1	Digital I/O EDAS, OEM Version
EDAS-1001E-2	Digital I/O EDAS, with RS-485 I/O
EDAS-1001G-2	Digital I/O EDAS, OEM Version, with RS-485 I/O
EDAS-1001E-SK1	Digital I/O EDAS Starter Kit, 90-120 VAC
EDAS-1001E-SK2	Digital I/O EDAS Starter Kit, 230VAC

SPECIFICATIONS - EDAS-1001E SERIES

All Specifications are typical at 25°C unless otherwise noted.

PARAMETER	CONDITIONS	SPECIFICATION
DIGITAL I/O Number of Ports Input Levels Input Current (High Level/ Low Level) Output Levels Source/Sink	8 channels (bits) each Port 0-2 Port 3 Port 0-2 Port 3	4, programmable for input or output TTL-compatible (Schmitt Trigger) 20µA / 200µA 5µA / 5µA TTL compatible 15mA/ 24mA 15mA/ 64mA
COUNTERS General Purpose Number of Channels Max Input frequency High Speed Number of Channels Max Input frequency	 TTL-level input TTL-level input	24-Bit up to 32 250Hz 16-Bit 2 250kHz
SERIAL RS-232C Connector Communication Supply Voltages RS-485 (EDAS-1001E-2A) Connector Communication Isolation	 3k ohm Load 1 Minute	DE-9 Serial Asynchronous, ASCII ±6V TX 3-wire screw terminal block Serial Asynchronous, ASCII 1600Vrms
NETWORK INTERFACE Type		Ethernet 10Base-T (RJ45)
POWER Voltage Range Current Requirements	AC or DC 24VAC, No Load/1A Load ¹	15 to 28 VAC, 20 to 40 VDC 200mA/500mA
PHYSICAL CHARACTERISTICS Size Operating Temperature Range		6.00" D x 5.57" W x 1.52" H 15.24 cm D x 14.15 cm W x 3.86 cm H 0 to 50°C

NOTE: (1)The on-board power supply circuit can supply up to 1 A @5 VDC to termination panels through the 34-pin I/O connectors.

Figure 2: Termination and Signal Conditioning Options for EDAS-1001E SERIES
 (See Signal Conditioning & Termination Products Section for Details)

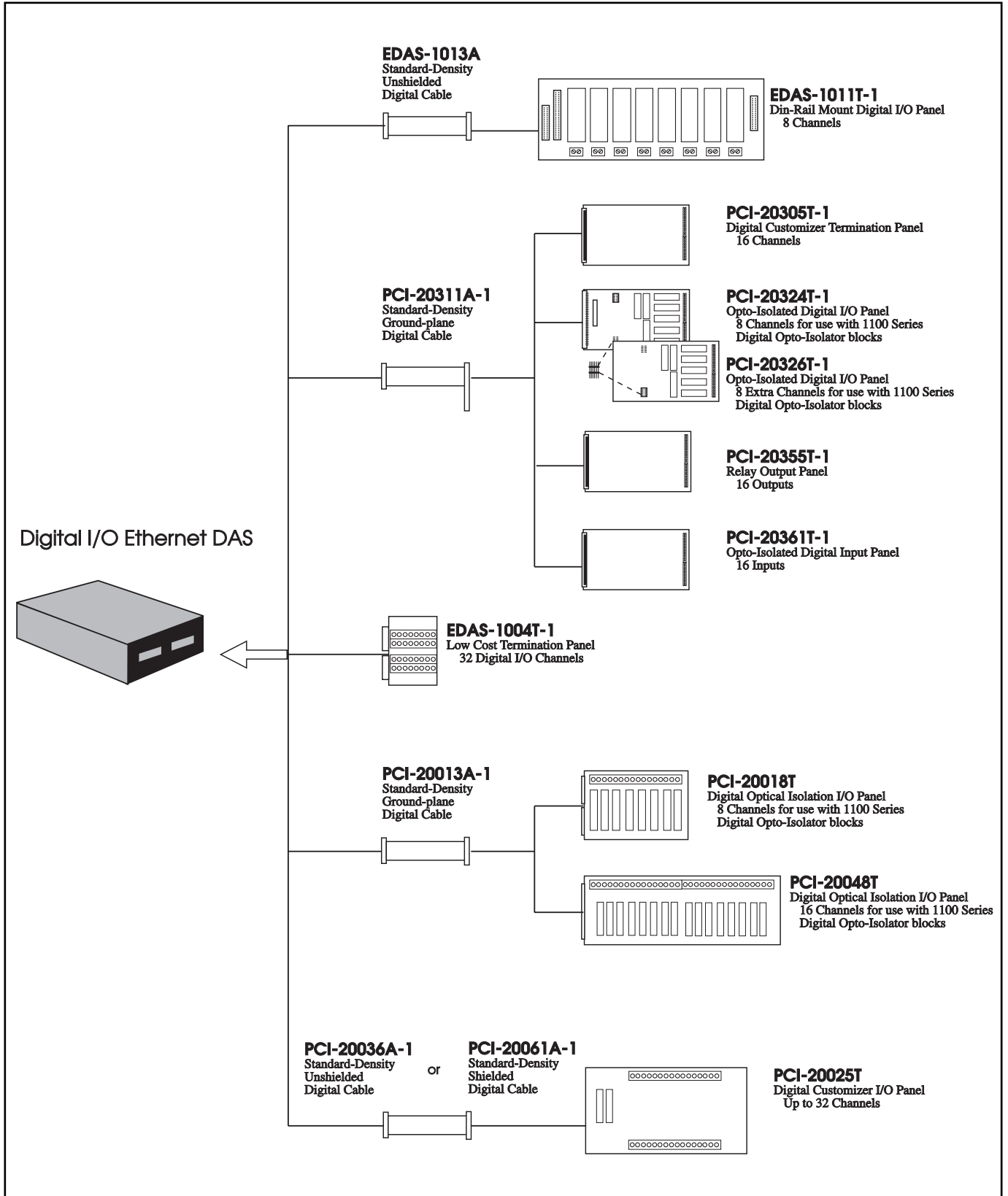

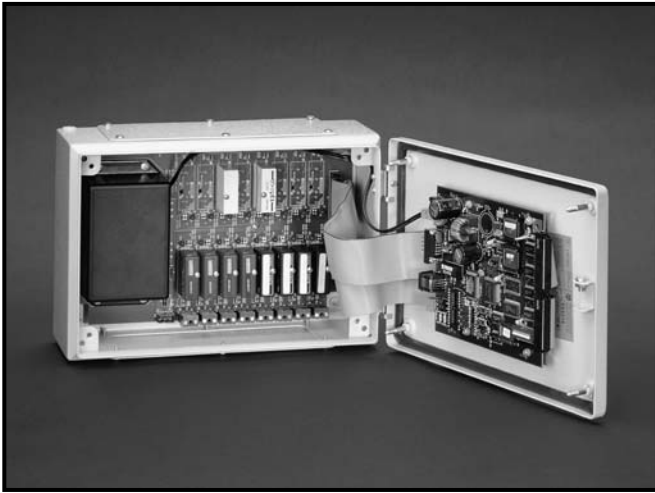

EDAS-1027E SERIES

INDUSTRIAL HARDENED DIGITAL I/O ETHERNET DATA ACQUISITION SYSTEM

TYPICAL APPLICATIONS

- ▲ Machine Monitoring and Control
- ▲ Production/Cycle Counting
- ▲ Remote Data Acquisition

KEY FEATURES/BENEFITS

- ▲ 16 programmable digital I/O channels
- ▲ PCI-1101 to 1106 series Opto-isolator modules provide isolated signal conditioning
- ▲ Two 16-bit counter channels perform frequency measurement
- ▲ Inputs can be programmed to read digital signal status, change-of-state and low speed event counting
- ▲ Outputs can be programmed for normal (on/off), delayed, and variable delay/pulse-width modes
- ▲ Up to 8 outputs can be configured for power up state

DESCRIPTION

The EDAS-1027E-1 is an industrial hardened EDAS that consists of a EDAS-1001E Digital I/O board, a custom termination panel and power supply. It is housed in a NEMA 12 Enclosure.

Digital I/O

Each EDAS-1027E provides 16 digital I/O channels, configurable in four byte-wide (8 bit) ports. Through the use of PCI-1101 to 1106 series isolated signal conditioning modules, I/O ranges of 10 to 280 volts are supported. The EDAS-1027E supports a number of digital I/O functions.

Inputs can be used to read the current status of digital signals, detect digital signal state-changes (latch a state), and count signal state-changes for low speed counting applications (less than 100 Hz).

Outputs can operate in simple on/off fashion, or can be programmed for specific delay times and on/off times for control and timing applications. In addition, eight of the digital output channels can be individually configured for predetermined output states at power-up.

Enclosure

The EDAS-1027E is housed in a NEMA-12 rated enclosure, making it suitable for industrial indoor use and providing protection from dust and non-corrosive liquid drip. The enclosure houses any PCI-1101 to 1106 series Opto-isolator modules your application requires. It comes with two blank side flanges that can be punched for routing cables and wiring. The hinged lid provides easy access to the circuit boards.

ORDERING INFORMATION

EDAS-1027E-1	Digital I/O EDAS
EDAS-1027E-2	Digital I/O EDAS, with RS-485 I/O

SPECIFICATIONS - EDAS-1027E SERIES

All Specifications are typical at 25°C unless otherwise noted.

PARAMETER	CONDITIONS	SPECIFICATION
POWER		
Voltage Range	Jumper selectable	120VAC or 240VAC
Current Requirements	16 modules	100mA
	No modules	135mA
PHYSICAL CHARACTERISTICS		
Size		11.81" L x 7.82" W x 4.72" D 300 cm L x 200 cm W x 120 cm D

NOTE: See the EDAS-1001E for additional specifications on digital I/O, serial interface, counters and Network interface.



TYPICAL APPLICATIONS

- ▲ Environmental Monitoring and Control
- ▲ Process Monitoring and Control
- ▲ Production Monitoring
- ▲ Remote Data Acquisition and Instrumentation

KEY FEATURES/BENEFITS

- ▲ 16SE/8DIFF Analog Inputs at -
 - 16-Bit Resolution - EDAS-1031E
 - 12-Bit Resolution - EDAS-1002E
- ▲ Up to 100kHz Sample Rate for EDAS-1002E
- ▲ Up to 40kHz Sample Rate for EDAS-1031E
- ▲ Two 12-Bit Analog Output Channels
- ▲ 16 Digital I/O Channels
- ▲ Digital inputs can be programmed to read digital signal status, change-of-state and to perform general-purpose event counting
- ▲ Digital outputs can be programmed for normal (on/off), delayed, variable delay/pulse-width and square wave modes
- ▲ One programmable 16-bit counter performs frequency measurement, high-speed event counting up to 250 kHz
- ▲ One RS-232 port monitors and controls instruments, gauges, smart sensors, machines and terminals
- ▲ One RS-485 port monitors and controls instruments, smart sensors and machines
- ▲ Synchronous and asynchronous client/server communications

EDAS-1031E SERIES and EDAS-1002E SERIES

MULTIFUNCTION ETHERNET DATA ACQUISITION SYSTEMS

- ▲ Net Link drivers for Windows available with complete documentation
- ▲ COM Port Drivers for Windows

DESCRIPTION

The high-accuracy EDAS-1031E Series and the EDAS-1002E Series Multifunction I/O Ethernet Data Acquisition Systems are members of a new family of products that provide remote I/O capabilities over Ethernet LAN's and the Internet.

Analog I/O

The EDAS-1031E Series and EDAS-1002E Series can be configured for 16 single-ended or for 8 differential analog input channels through software. The EDAS-1031E Series unit provides high-accuracy 16-bit resolution for the analog input channels and the EDAS-1002E Series offers analog input channels with 12-bit resolution.

Both units are also equipped with two analog output channels. They provide voltage outputs at 12-bit resolution with a ± 10 V output range.

One rate generator is also provided for pacing analog input acquisitions. The timebase for the rate signal is derived from an internal 4 MHz crystal oscillator, allowing rates from 0.001 Hz to 100 kHz to be programmed.

Digital I/O

The EDAS-1031E and EDAS-1002E Series provide 16 TTL compatible digital I/O channels. Digital I/O channels are programmable in two byte-wide (8-bit) sections, or ports. Through local signal processing, various digital input/output functions are supported. Digital inputs can be used to read the current status of digital signals, detect signal state-changes (latch a state), and count events up to 250 Hz. Outputs can operate in simple on/off fashion, or can be programmed for specific delay times and on/off times for control and timing applications. All inputs and outputs are protected from damage under power on and power off conditions.

High-Speed Counters

The EDAS-1031E and EDAS-1002E Series include one 16-bit high-speed counter channel. The input of this counter is made available

by multiplexing it with one of the digital input lines. This counter can perform high-speed event counting on TTL level signals up to 250kHz. Additionally, the counter can perform direct frequency measurements.

Serial I/O

EDAS systems also feature serial I/O capabilities. An on-board RS-232 port can be used for both configuration and I/O applications. When the RS-232 port is in "Configuration Mode", any terminal device or computer with an RS-232 port can be used to program the unit's IP address, subnet mask and gateway parameters. With the port in "Command Mode", EDAS units can monitor and control almost any device with RS-232 connectivity, including instruments, scales, gauges, smart sensors, machines and terminals.

EDAS systems which feature RS-485 I/O capabilities are also available. In addition to analog, digital and RS-232 I/O capabilities, these units monitor and control any number of instruments, sensors, and machines with RS-485 connectivity.

Operation

EDAS units act as application servers, providing I/O functions to clients on the network. They operate in both synchronous and asynchronous mode. In synchronous mode, a client polls the unit for digital input values and counter data, or to set outputs. Asynchronous mode allows the unit to send data based on alarm conditions.

Termination Signal Conditioning

The EDAS-1031E and EDAS-1002E interface to real world signals through one 50-pin connector, giving you access to a wide variety of termination products and signal conditioning options. Refer to the Termination and Signal Conditioning Products for EDAS Section.

OEM Version

OEM Versions of EDAS systems are available to those who wish to incorporate this innovative design into a larger system. These "board-only" versions come without the rugged external case,

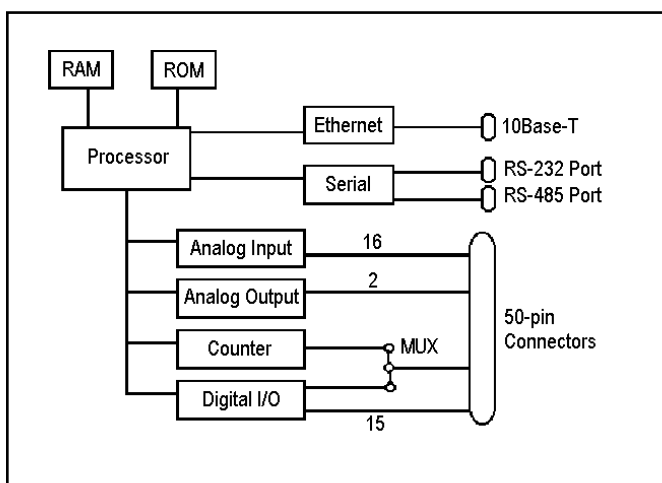

Figure 3: EDAS-1002E Series Block Diagram

allowing the circuit board to be mounted in an enclosure of your choice.

Starter Kits

FactoryView Starter Kits contain everything you need to begin performing remote I/O with your EDAS system.

- ▲ 1 EDAS unit
- ▲ 1 termination panel
- ▲ 1 DIN-rail mounting kit
- ▲ 1 power adapter
- ▲ Cabling
- ▲ COM Port Drivers for Windows
- ▲ Net Link Software Libraries for Windows
- ▲ SYSCHECK Diagnostic/Utility Software
- ▲ Complete documentation

EDAS-1002E-SK1 and EDAS-1031E-SK1 (Multifunction) Kits include a 90-120VAC power adapter. For 230VAC power requirements, order the EDAS-1002E-SK2 or EDAS -1031E-SK2 kit.

ORDERING INFORMATION

EDAS-1031E-1A	16-bit Multifunction I/O EDAS
EDAS-1031E-1AG	16-bit Multifunction I/O EDAS, OEM Version
EDAS-1031E-2A	16-bit Multifunction I/O EDAS , with RS-485 I/O
EDAS-1031E-2AG	16-bit Multifunction I/O EDAS , OEM Version with RS-485 I/O
EDAS-1031E-SK1	16-bit Multifunction I/O EDAS Starter Kit, 90-120 VAC
EDAS-1031E-SK2	16-bit Multifunction I/O EDAS Starter Kit, 230 VAC
EDAS-1002E-1A	Multifunction I/O EDAS
EDAS-1002E-1AG	Multifunction I/O EDAS, OEM Version
EDAS-1002E-2A	Multifunction I/O EDAS, with RS-485 I/O
EDAS-1002E-2AG	Multifunction I/O EDAS, OEM Version, with RS-485 I/O
EDAS-1002E-SK1	Multifunction I/O EDAS Starter Kit, 90-120 VAC
EDAS-1002E-SK2	Multifunction I/O EDAS Starter Kit, 230 VAC

All Specifications are typical at 25°C unless otherwise noted.

PARAMETER	CONDITIONS	EDAS-1031E SPECIFICATION	EDAS-1002E SPECIFICATION
ANALOG INPUTS			
Number of Channels	Single-ended Differential	16 8	16 8
Resolution		16-bits (1 part in 65,536)	12-bits (1 part in 4,096)
Voltage Ranges	Gain = 1 Gain = 10 Gain = 100	0 - 10V, ±10V 0 - 1V, ±1V 0 - 0.1V, ±0.1V	0 - 10V, ±10V 0 - 1V, ±1V 0 - 0.1V, ±0.1V
Overvoltage Protection	Power on/ Power off	±35V/ ±20V	±35V/ ±20V
Gain Accuracy ¹	Gain = 1 Gain = 10 Gain = 100	.05% .05% .05%	.012% .05% typ, 0.25% max .05% typ, 0.25% max
Offset Voltage	RTI	3mV	3mV
Input Impedance		10 ¹⁰ ohms / 100 pF	10 ⁹ ohms / 50 pF
Common Mode Range	Vcm = Vrange - (Vdiff * Gain)/2	±10V (DC + Peak AC) min	±10V (DC + Peak AC) min
Rejection	60Hz, 100 ohm imbalance Gain = 1 Gain >=10	-85dB -90dB	-85dB -90dB
Noise	RMS	1.0 LSB	1.0 LSB
Linearity Error	Integral	.005%	.024%
ANALOG OUTPUTS			
Number of Channels		2	2
Resolution		12 bits (1 part in 4096)	12 bits (1 part in 4096)
Voltage Ranges		±10V	±10V
DIGITAL I/O			
Number of Ports	8 channels (bits) per port	2	2
Input Levels		TTL-compatible (Schmitt Trigger)	TTL-compatible (Schmitt Trigger)
Input Current (High Level/ Low Level)	Port 0 Port 1	20µA / 200µA 5µA / 5µA	20µA / 200µA 5µA / 5µA
Output Levels		TTL compatible	TTL compatible
Source/Sink	Port 0 Port 1	15mA/ 24mA 15mA/ 64mA	15mA/ 24mA 15mA/ 64mA
COUNTERS			
General Purpose		24-Bit	24-Bit
Number of Channels	TTL-level input	up to 16	up to 16
Max Input frequency		250Hz	250Hz
High Speed		16-Bit	16-Bit
Number of Channels	TTL-level input	1	1
Max Input frequency		250kHz	250kHz
TIMEBASE GENERATOR			
Type	Crystal-based	Rate Generator (32-bit)	Rate Generator (32-bit)
Number		1	1
Resolution		125 ns	125 ns
Output Frequency Range		0.001 Hz to 1 Mhz	0.001 Hz to 1 Mhz
SERIAL			
RS-232C			
Connector		DE-9	DE-9
Communication		Serial Asynchronous, ASCII	Serial Asynchronous, ASCII
Supply Voltages	3k ohm Load	±6V TX	±6V TX
RS-485			
Connector		3-wire screw terminal block	3-wire screw terminal block
Communication		Serial Asynchronous, ASCII	Serial Asynchronous, ASCII
Isolation	1 Minute	1600Vrms	1600Vrms
NETWORK INTERFACE			
Type		Ethernet 10Base-T (RJ 45)	Ethernet 10Base-T (RJ 45)
POWER			
Voltage Range	AC , DC	15 to 28 VAC, 20 to 40 VDC	15 to 28 VAC, 20 to 40 VDC
Current Requirements ¹	24 VAC, No Load/24 VAC, 1A Load	350mA/650mA	350mA/650mA
PHYSICAL CHARACTERISTICS			
Size		9.0" D x 7.0" W x 1.5" H (approx.) 22.28 cm D x 17.78 cm W x 3.81 cm H	9.0" D x 7.0" W x 1.5" H (approx.) 22.28 cm D x 17.78 cm W x 3.81 cm H
Operating Temperature Range		0 - 50°C	0 - 50°C

NOTE: (1)The on-board power supply circuit can supply up to 1Amp at 5VDC to termination panels through the 50-pin I/O connector.
'gain = 1 factory calibrated

Figure 4: Termination and Signal Conditioning Options for EDAS-1031E & EDAS-1002E SERIES
 (See Signal Conditioning & Termination Products Section for Details)

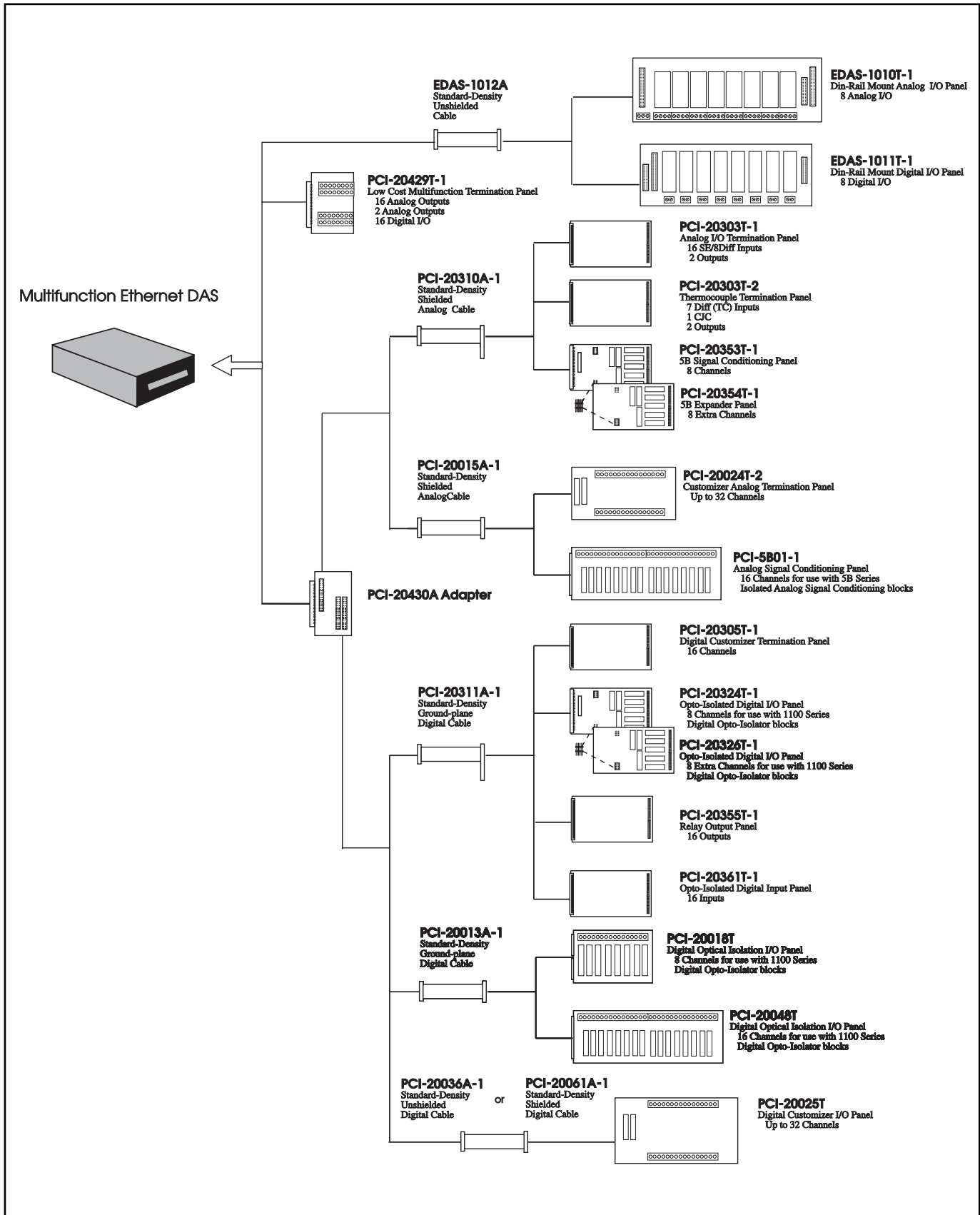



TYPICAL APPLICATIONS

- ▲ Embedded Ethernet interface for equipment and instruments that currently have serial interfaces
- ▲ Ethernet access to PLC's
- ▲ Automated machine monitoring
- ▲ Ethernet access to remote terminals
- ▲ Remote data acquisition
- ▲ Security and access control

KEY FEATURES/BENEFITS

- ▲ General
 - Provides remote access to RS-232 devices via Ethernet
 - TCP/IP communication protocol allows access over Internet or intranets
 - 2 and 4 RS-232 serial port versions
 - Embeddable for OEM applications
 - Reduces wiring costs - uses existing Ethernet wiring
 - Allows network access to a wide range of devices including: PLC's, controllers, instruments, scales, gauges, smart sensors, machines, terminals and scanners
- ▲ Communications
 - Networked Ethernet access to serial devices
 - Direct 10Base-T Ethernet interface
 - Built-in TCP/IP protocol for communications
 - Interfaces serial devices to network resources and plantwide software

EDAS-1025E SERIES

SERIAL-TO-ETHERNET CONVERTER

- Synchronous and asynchronous client/server communications
- ▲ Physical
 - Compact efficient design
 - Operates on wide range of power
 - Board-only versions available for embedded applications
- ▲ Software Support
 - Net Link drivers for Windows
 - COM Port Drivers for Windows

DESCRIPTION

The EDAS-1025E Ethernet/Serial Interface is a member of our EDAS family of low-cost data acquisition and interface products that communicate with PC's and other computers over Ethernet and the Internet. They utilize the open systems environment of Ethernet to interface data from any number of remote locations. Data can then be made available for use by other networked resources or for further processing by plantwide software and/or databases, including your intranet or Internet information pages.

Open System

EDAS units communicate over any Ethernet network (LAN) using the industry-standard TCP/IP protocol, providing a non-proprietary interface to virtually any host. Each EDAS unit has a TCP/IP protocol 'stack' built-in and receives its own unique network IP address, configured through one of its on-board RS-232 serial ports.

Serial EDAS

Each serial port on an EDAS-1025E system interfaces with almost any device which communicates via RS-232, including PLC's, controllers, instruments, scales, gauges, smart sensors, machines, terminals and scanners. The EDAS-1025E enables any of these devices to communicate with computers located anywhere on an Ethernet network.

Operation

EDAS-1025E systems act as application servers, providing remote serial I/O to clients on the network. They operate in both synchronous and asynchronous mode.

When in synchronous mode, the EDAS-1025E sends any data received on its serial port to a client application when the client polls the unit for serial data. When in asynchronous mode, the EDAS-1025E sends any serial data to the client application in response to a programmable transmit condition.

OEM Version

OEM Versions of the EDAS-1025E are available to those who wish to incorporate this innovative design into a larger system. These "board-only" versions allow the circuit board to be mounted directly into your equipment. OEM versions are powered from +5VDC.

ORDERING INFORMATION

EDAS-1025E-1B1*	2 port serial EDAS (120 VAC)
EDAS-1025E-1B2*	2 port serial EDAS (230 VAC)
EDAS-1025N-1B1	2 port serial EDAS (120 VAC)
EDAS-1025N-1B2	2 port serial EDAS (230 VAC)
EDAS-1025G-1B	2 port serial EDAS (OEM version)
EDAS-1025E-2B1*	4 port serial EDAS (120 VAC)
EDAS-1025E-2B2*	4 port serial EDAS (230 VAC)
EDAS-1025N-2B1	4 port serial EDAS (120 VAC)
EDAS-1025N-2B2	4 port serial EDAS (230 VAC)
EDAS-1025G-2B	4 port serial EDAS (OEM version)

* Includes: Net Link Software Libraries, COM Port Drivers for Windows, Hardware Manual and DB9 Null Modem Cable

SPECIFICATIONS - EDAS-1025E SERIES

All Specifications are typical at 25°C unless otherwise noted.

PARAMETER	CONDITIONS	SPECIFICATION
SERIAL RS-232C Connector Communication Supply Voltages Baud Rate	3k ohm Load	2 or 4 ports DE-9 ASCII, Binary ±6V TX , RTS Active 300-115K Baud
NETWORK INTERFACE Type		Ethernet 10Base-T (RJ45)
POWER Voltage Range -1, -2 G-1B, G-2B (OEM ver.)	AC or DC DC	15 to 28 VAC, 20 to 40 VDC +5 VDC
PHYSICAL CHARACTERISTICS Size -1, -2 G-1B, G-2B (OEM ver.)		5.125" D x 7.70" W x 1.70" H 13.0 cm D x 19.56 cm W x 4.32 cm H 4.50" D x 7.00" W x 1.10" H 11.43 cm D x 17.78 cm W x 2.79 cm H
Operating Temperature Range		0 to 50°C

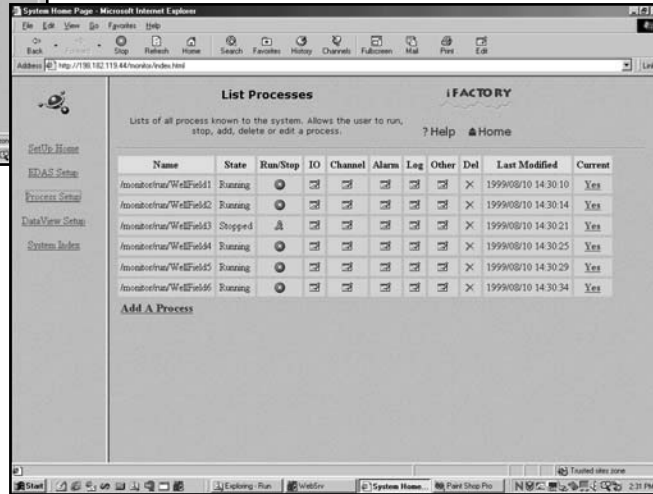
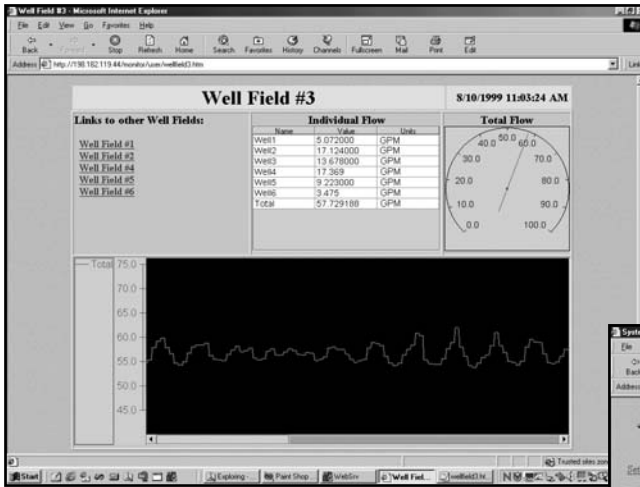

iFactory Monitor is a unique way to monitor machines, equipment and processes on the factory floor. iFactory Monitor leverages standard Internet technology to provide fully configurable, full-featured real-time solutions for remote monitoring. It is built around a web server with dynamic HTML and scripting capabilities that include direct access to digital I/O, analog I/O, and serial ports, as well as ODBC databases. It allows direct set-up, configuring and viewing of real-time data and events using a standard web browser.

The iFactory Monitor application software pulls together the easy-to-use browser interface with real-time monitoring to provide distributed universal access to almost any device or process. Graphical and tabular viewing of real-time data, logging, alarms and control are all built into the application. If you can surf the web, you can now track machines, equipment and processes from any computer on the Internet. iFactory Monitor is ideal for remote, embedded and distributed monitoring requirements such as data logging, machine monitoring, equipment utilization, remote power management, security and energy management systems.

To build an iFactory application, the user simply uses a browser interface to iFactory running on the EDAS to build a process consisting of reading/writing I/O, processing, logging, alarming and

database access. Processes can be setup to run once or at a specified rate. Setting up a Process is done by working through a set of forms that guide you through the building of customized monitoring applications. A Process is built out of high level functions (see next page). In addition, the advanced user can choose to include DHTML script statements in their process.

Once a Process has been built, iFactory walks the user through building a customized HTML page for "real-time" display of Process variables. iFactory includes applets (see next page) that provide real-time display capability at the browser.

iFACTORY MONITOR

INTERNET TECHNOLOGY FOR THE FACTORY

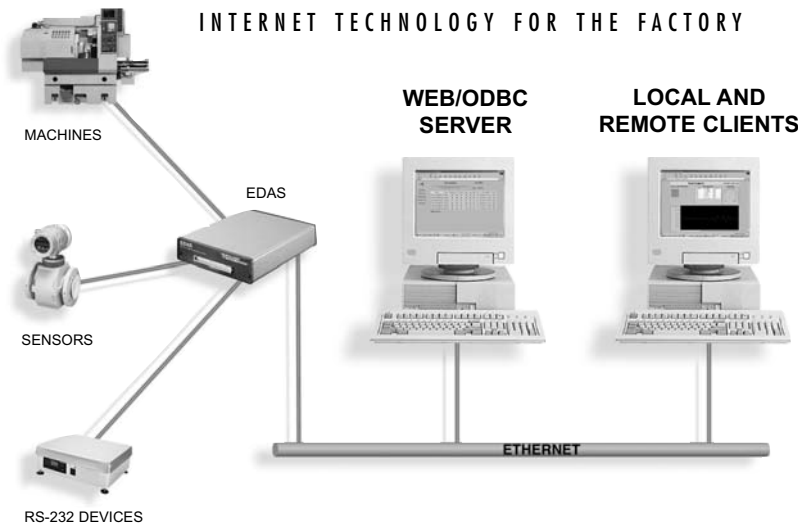

Applet	Description
Alarm Applet	Provides real-time alarm capabilities
Chart Applet	Line Chart that will display multiple traces real-time
Meter Applet	Analog meter for displaying real-time data
Panel Applet	Displays a single data element
Table Applet	Displays a list of process values

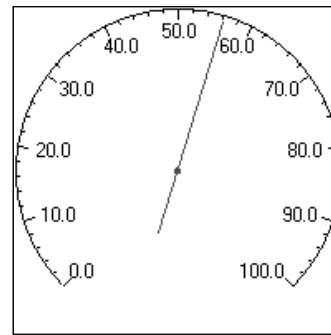

Meter Applet

Name	Value	Units
Temperature	73.986800	
potIN	56.359860	
AnalogBit1	0.296326	

Table Applet



Alarm Applet

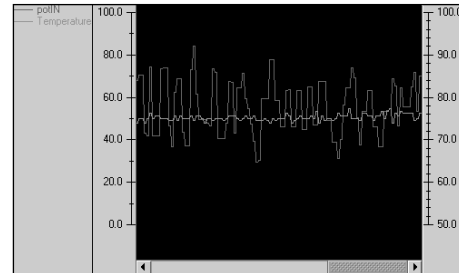
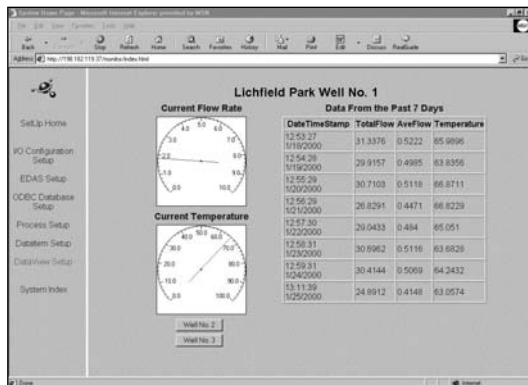

Chart Applet

Typical Applications

Remote Well Monitoring

See what is going on at your well sites with a virtual visit. Why make the drive or spend the money to send someone to the site when you can see what is happening right from your desk.



Remote Well Monitoring

Facilities Monitoring

Use the alarm capability to monitor simple switches or calculated process variables, in real-time over your company network, Intranet or Internet.

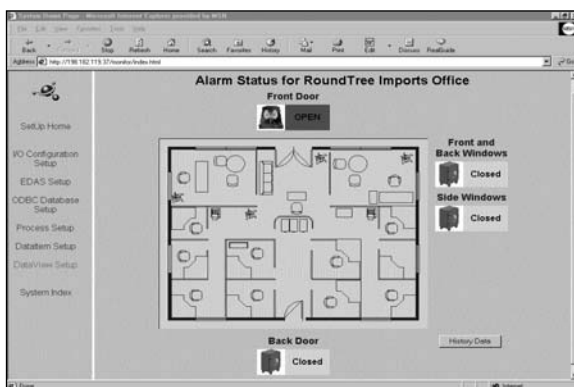

Facilities Monitoring

SPC Control

Monitor your machines and processes, feed the data to an ODBC database, sound an alarm if the product is out of specification, get notified by email if the machine goes off line or needs attention.

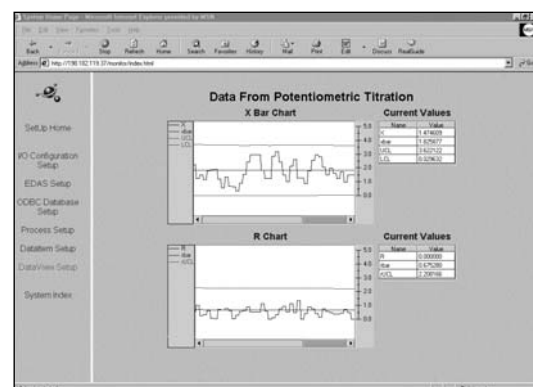

SPC Control

iFactory Function	Description
Absolute Value	.Calculates the absolute value of its input
Add	.Sums a maximum of 8 operands
Alarm	.This alarm allows set acknowledge and clear functions
AND	.Performs a logical AND (maximum of 8 operands)
Append	.Appends a maximum of 8 strings together
Bang Bang Controller	.Implements a simple bang-bang control
Cycle Time	.Calculates the time required to process a unit
DBToTable	.Reads an ODBC database and returns the data in an HTML table
Delay	.Delays the execution of a process
Divide	.Divides an operand by a maximum of 7 other operands
Down Counter	.Decrements the last output by its input
Derivative	.Calculates the derivative of its input
email	.Sends an email that may contain current process data
Extract	.Extracts a sub-string from its input string
Fetch	.Reads the value of a variable in another process
Get URL	.Retrieves a resource from another web server
html	.Generates an HTML or text string
If	.Performs conditional processing on the process
Integral	.Calculates the integral value of its input
LogtoDB	.Logs process data to an ODBC database
LogtoFile	.Logs process data to a file
Maximum	.Outputs the maximum value of the input
Minimum	.Outputs the minimum value of the input
Moving Average	.Average of the past N input values
Multiply	.Able to multiply a maximum of 8 operands
$M * X/D + B$	$M * X / D + B$
NAND	.Performs a logical NAND (maximum of 8 operands)
NOR	.Performs a logical NOR (maximum of 8 operands)
NOT	.Performs a Boolean swap of values
OR	.Performs a logical OR (maximum of 8 operands)
Power	.Calculates X raised to the Y power
Print Console	.Appends a maximum of 8 strings together and prints it to the console
Process Running	.Allows a process to determine if another process is running
Put	.Updates the value of a variable in another process
Random	.Random number generator
Read AI	.Reads the Analog inputs on an EDAS
Read DataBase	.Reads one record at a time from an ODBC database
Read DI	.Reads a digital input port on an EDAS
Read Serial	.Reads the serial port on an EDAS
Retain Data	.Retains Process Data between executions
Run Process	.Runs a child process from within a process
Run Program	.Runs a Program on the server
Script	.Allows addition of custom scripts to a process
Set	.Changes the value of a Process variable
SPC	.Statistical Process Control
Square	.Square of the input
Square Root	.Square Root of the input
Subtract	.Subtracts a maximum of 7 operands from the first operand
Trig (Sin, Cos, Tan)	.Calculates the Sin, Cos, Tan, ArcSin, ArcCos or ArcTan
Trigger DO	.Triggers Digital outputs on EDAS
Up Counter	.Sums the input with the last output
Up / Down Time	.Accumulates the up, down and total time based on its input value
Variable	.Creates a new Process variable
Weighted Average	.Calculates an output based on a weighted value of the input and output
Write AO	.Writes to the Analog Output port on an EDAS
Write DO	.Writes to the Digital Output port on an EDAS
Write Serial	.Writes to the serial port on an EDAS

SOFTWARE SUPPORT

DIAGNOSTIC

SYSCHECK for EDAS (EDAS-1006S-1) - SYSCHECK is an easy-to-use system assurance and diagnostic package for Windows. You can use SYSCHECK to quickly verify whether or not your hardware is functioning properly. Additionally, SYSCHECK can be used to configure the TCP/IP address, gateway address and subnet mask of each EDAS unit in your system. SYSCHECK software is available free of charge.

NET LINK SOFTWARE LIBRARIES / DRIVERS

These libraries are available for developing custom EDAS applications using standard programming languages. Simple, high-level commands eliminate the need for long sequences of bit-oriented, register-specific program sections. All library function calls return an integer result, or error code, indicating the success or failure of the action taken. Complete documentation and examples describing the Application Programming Interface are included.

Net Link Software Library for Windows 9x/NT/XP/2000

(EDAS-1003S-4) - This library facilitates the development of EDAS applications running in a 32-bit Windows environment. The drivers are provided in the form of dynamic link libraries (DLLs). The library supports Microsoft and Borland C/C++ compilers and Microsoft Visual Basic.

ACCESSORIES FOR EDAS

DIN-Rail Mounting Kit (EDAS-1005A-1) - This kit provides all the hardware necessary to easily mount one EDAS unit on an industry-standard DIN rail.

Industrial Enclosure (EDAS-1024A) - This industrial enclosure is designed to house the Multifunction and Digital EDAS Ethernet data acquisition systems along with any signal conditioning/ isolation modules your application requires. Designed for wall-mounting, the 16-gauge black or grey steel enclosure includes all of the mounting holes and accessories to mount your EDAS board and termination panels. The enclosure measures 14.50" x 10.25" x 5.25", and provides 8 pluggable holes for cable routing through 1/2" conduit (conduit not included). A removable lid provides access to the internal circuitry from the front of the unit. The lid is fastened to the enclosure with 8 screws and provides four 2-3/4" gaskets for additional discrete wiring. For your termination and signal conditioning requirements, the enclosure houses up to four EDAS-1010T-1 (Analog) and EDAS-1011T-1 (Digital) termination panels in any combination (see page 17). These panels accommodate industry-standard PCI-5B series analog and PCI-1100 series Opto-style digital isolation blocks (see page 19).

ETHERNET/SERIAL COMMUNICATIONS SOFTWARE

COM Port Driver for Windows NT/2000 (EDAS-1032S-1)

COM Port Driver for Windows 95/98/ME (EDAS-1032S-2)

The EDAS COM Port Drivers connect to, configure and communicate with remote EDAS COM ports over Ethernet, allowing users to communicate with these ports as if they were local COM ports using their existing applications programs. Most software packages which include serial communications capabilities can take advantage of this driver. Some examples include popular SCADA software packages, data acquisition software and serial communications software such as HyperTerminal, ProComm, and Kermit. The COM Port driver supports all serial ports on any EDAS unit, allowing you to communicate with remotely located instruments, scales, barcode scanners, machines, and other serial devices.

RS-232 Data Transfer Cable (LPA015) - Use to program EDAS systems with the IP address, gateway address and subnet mask. The cable connects to the unit's RS-232 connector and has a DE-9 and DB-25 connector at each end.

AC Power Adapter, 90-120VAC (LPP002) - UL and CSA approved power supply accepts input voltage from 90-120 VAC and provides 24 VAC at 1.2A. Power supply connects to EDAS System with 2-pin screw connector.

AC Power Adapter, 230VAC (LPP003) - This VDE approved power supply accepts input voltage from 230 VAC through an IDE connector and provides 24 VAC at 1.2A to your EDAS system. The supply is fitted with a 2-pin screw terminal connector to connect directly to EDAS units.

TERMINATION & SIGNAL CONDITIONING PRODUCTS

A variety of products are available from Intelligent Instrumentation to provide connection from EDAS units to real-world signals.

LOW-COST TERMINATION PANELS

Low-Cost Digital Termination Panel (EDAS-1004T-1) - This panel plugs directly into the I/O connector of the Digital I/O EDAS (EDAS-1001E-1), giving you 32 channels of digital I/O. Stand-out screws allow you to secure the panel to the EDAS-1001E-1 without the use of a cable.

Low-Cost Multifunction Termination Panel (PCI-20429T-1) - This panel plugs directly into the I/O connector of the Multifunction EDAS (EDAS-1002E-1), giving you 16 analog input channels, 2 analog output channels and 16 channels of digital I/O. Stand-out screws allow you to secure the panel to the EDAS-1002E-1 without the use of a cable.

DIN-RAIL MOUNT TERMINATION PANELS

Designed for use in industrial applications, these panels can be mounted directly onto walls, cabinet panels or machinery through the use of DIN-rails. The panels include DIN-rail adapters which allow them to be mounted directly to any industry-standard DIN-rails.

These panels offer a great deal of flexibility for user configuration. They allow a mix of inputs and outputs as well as a mix of conditioned and non-conditioned channels on the same panel. The panels incorporate expansion connectors so that they can be daisy-chained in combination with each other to terminate all of the analog inputs and digital I/O channels of an EDAS unit. They also feature pluggable, quick-disconnect field wiring connectors for ease of wiring and assembly.

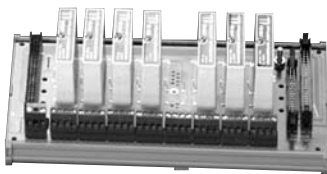
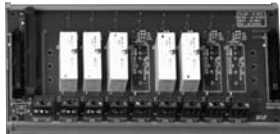

DIN-Rail Mount Panels

DIN-Rail Mount Analog I/O Panel (EDAS-1010T-1) - EDAS-1010T-1 Analog I/O Panels can be cascaded to accommodate all of the analog I/O channels of an EDAS unit. Additionally, the panels can be cascaded with EDAS-1011T-1 Digital I/O Panels for a mix of analog and digital I/O channels. Each EDAS-1010T-1 panel accommodates up to 8 channels in any combination of inputs or outputs. Conditioned and non-conditioned channels can be mixed on the panel. The panel accepts any of the 5B series isolated signal conditioning blocks so isolation/signal conditioning can be performed on any of the channels. On channels where isolation/signal conditioning is not desired, the 5B socket can be bypassed by inserting jumpers.

DIN-Rail Mount Digital I/O Panel (EDAS-1011T-1) - EDAS-1011T-1 Digital I/O Panels can be cascaded to accommodate all of the digital I/O channels of any EDAS unit. Additionally, the panels can be cascaded with EDAS-1010T-1 Analog I/O Panels for a mix of analog and digital I/O channels. Each EDAS-1011T-1 panel accommodates up to 8 channels in any combination of inputs or outputs. Isolated and non-isolated channels can be mixed on the panel. The panel accepts any of the PCI-1100 series Opto-style digital isolator blocks, which provide optical isolation between channels, sense voltage levels and control load switching. On channels where isolation is not desired, the opto-isolator socket can be bypassed by inserting jumpers.

DIN-Rail Mounting Tray for Termination Panels

(EDAS-1014A-1) - This tray provides an elegant, sturdy enclosure for the termination panel while protecting it from any potential which may exist on the equipment to which the panel is mounted. The EDAS-1014A-1 holds one EDAS-1011T-1 or EDAS-1012-1 panel and mounts directly onto any industry-standard DIN-rail.

3U TERMINATION PANELS & ENCLOSURES

These panels conform to the 3U form factor, allowing them to support higher channel densities at a lower cost. Additionally, most of our 3U digital panels are available in quick-disconnect versions, with pluggable screw terminals that reduce wiring and assembly time.

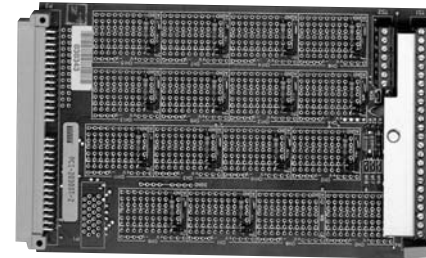

PCI-20303T Panel

Analog Panels

3U Analog I/O Panel (PCI-20303T-1,-2) - The PCI-20303T-1 supports 16 single-ended or 8 differential analog inputs and 2 analog outputs. The PCI-20303T-2 features cold-junction compensation (CJC) circuitry to support thermocouple inputs. When the CJC function is activated, the panel supports 7 differential analog inputs, 1 CJC, and 2 analog outputs.

3U 5B Analog I/O Panels (PCI-20353T-1 and PCI-20354T-1)

These termination panels support industry-standard 5B Series analog signal conditioning blocks, which interface to a variety of signal sources and provide an isolated channel of analog input or output. The PCI-20353T-1 termination panel provides eight analog I/O channels; you can expand the channel capacity to 16 by connecting a PCI-20354T-1 Termination Panel Expander to it.

Digital Panels

3U Digital I/O Panel (PCI-20305T-1) - The standard density PCI-20305T-1 panel provides 16 terminals and signal conditioning circuit board areas that can be used for digital I/O.

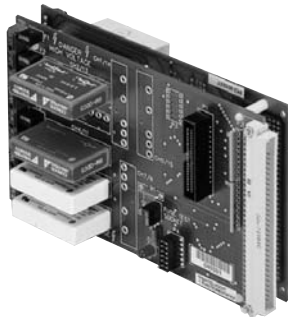

PCI-20324T Panel & PCI-20326T Expander

3U Opto-Isolator Digital I/O Panels (PCI-20324T and PCI-20326T)- These panels are used in conjunction with the PCI-1107 through -1112 series of slim-line Digital Opto-Isolator blocks. Each module provides up to 4000 volts isolation and converts a single channel of voltage between a real-world level and a TTL-level signal used by data acquisition systems. Refer to the Isolator Modules section on page 19 for information on these modules. The PCI-20324T-1 has a standard-density connector and provides eight digital I/O channels. You can expand channel capacity to 16 channels using the PCI-20326T-1 Expander Panel, which can be interfaced to the base panel via an inter board connector cable. The PCI-20324T-2 and PCI-20326T-2 are quick-disconnect versions of these panels.

3U Opto-Isolator Switchable Digital I/O Panel (PCI-20486T-1) - Like the PCI-20324T and PCI-20326T panels, this panel is used in conjunction with the PCI-1107 through -1112 Opto-Isolator blocks, which plug directly onto the termination panel. Each module provides up to 4000 volts isolation and converts a single channel of voltage between a real-world level and a TTL-level signal used by data acquisition systems. The PCI-20486T-1 provides eight digital I/O channels which can be individually configured as either an input or an output through the use of on-board DIP switches. Its ability to mix digital inputs and outputs on the same termination panel provides a greatly reduced cost per channel in many applications which would previously have required two termination panels. The termination panel is equipped with the popular quick disconnect-style wiring terminals. These screw terminals are easily unplugged and removed from the termination panel, allowing a user easy access to the wiring blocks for wiring and assembly. The PCI-20486T-1 has both a low-density and a high-density connector to provide a direct connection to all of Intelligent Instrumentation's popular data acquisition boards and systems.

3U Digital Relay Output Panel (PCI-20355T) - The PCI-20355T-1 termination panel is a 16-channel digital output panel that accommodates plug-in DIP relays to switch a connected load. Kits of 16 normally open (NO) reed relays (PCI-20359A-1) normally closed (NC) reed relays (PCI-20360A-1) are available for the panels and must be purchased and installed separately. The PCI-20355T-2 is a quick-disconnect version of this panel.

3U Opto-Isolated Digital Input Panel (PCI-20361T) - The PCI-20361T-1 provides both digital signal conditioning and isolation through separate opto-couplers built in to each channel. The panel supports 16 isolated inputs at the lowest possible cost per channel. The PCI-20361T-2 is a quick-disconnect version of this panel.

Enclosures

PCI-20308H-1 Enclosure - This enclosure is constructed of lightweight, extruded aluminum and can be installed in either a tabletop or 19-inch rack-mount configuration. Built-in card guides insure that the panels are properly aligned with the mating connectors at the rear of the cage. Depending on the height of any optional components installed on the termination panels, you can house up to 20 3U-sized panels in one enclosure. The enclosure is shipped with hardware for five panels (5 pairs of card guides, 5 card locks, and 15 cable/connector mounting screws). Hardware for an additional five panels is available in the PCI-20309A-1 Termination Panel Mounting Kit.

PCI-20348A-1 Enclosure - This enclosure holds up to three 3U-sized termination panels and is suitable for table-top and surface mount configurations.

GENERAL-PURPOSE TERMINATION PANELS & ENCLOSURES

These panels can be mounted in industry-standard 19-inch racks, or surface mounted in Intelligent Instrumentation enclosures.

Analog Panels

5B Analog I/O Panel (PCI-5B01-1) - The PCI-5B01-1 Analog Panel is a 16-channel panel that accepts any of the 5B Series isolated signal conditioning blocks. These blocks interface to a variety of signal sources and provide an isolated channel of analog input or output. A separate temperature sensor is mounted at each set of screw terminals of the panels to provide cold-junction-compensation (CJC) for thermocouples.

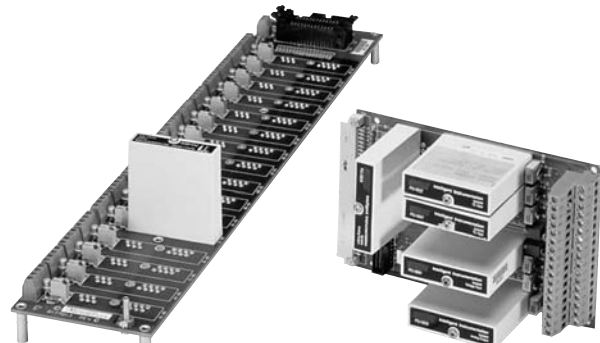

PCI-5B01 and PCI-20353T-1 Panels, with PCI-5B Series Blocks

Customizer Analog Termination Panel (PCI-20024T-2) - The PCI-20024T-2 Customizer Analog Termination Panel accommodates up to 32 channels of single-ended analog inputs or outputs, with signal conditioning available on each channel. Differential inputs can be connected by using single-ended channels in pairs, allowing up to 16 differential pairs per panel. A cold-junction compensation (CJC) temperature sensor is included on channel 4 for thermocouple applications. Input bias current return resistors are installed on all channels. This panel has a generic layout pattern, virtually any kind of passive or active network can be added to each individual channel.

Digital Panels

Isolated Digital Termination Panel (PCI-20018T-1) - The PCI-20018T-1 provides eight isolated digital I/O channels when used in conjunction with the PCI-1100 through -1106 series of Digital Opto-Isolator blocks. The blocks, which sense voltage levels and control load switching, plug directly onto the panel (one per channel), are available in six versions to satisfy a variety of

applications. Refer to the Isolator Blocks section for more information on PCI-1100 Series Digital Opto-Isolator Blocks. The PCI-20018T-1 can be surface-mounted or mounted in a PCI-20029A-1 enclosure (up to four panels per enclosure).

Isolated Digital Termination Panel (PCI-20048T-1) - The PCI-20048T-1 provides 16 isolated digital I/O channels when used in conjunction with the PCI-1100 through -1106 series of Digital Opto-Isolator blocks. The blocks, which sense voltage levels and control load switching, plug directly onto the panel (one per channel), are available in six versions to satisfy a variety of applications. Refer to the Isolator Blocks section for more information on PCI-1100 Series Digital Opto-Isolator Blocks. Use the PCI-20339A-1 enclosure to mount the panel.

Customizer Digital I/O Termination Panel (PCI-20025T-2) - The PCI-20025T-2 accommodates up to 32 channels of digital inputs or outputs, with signal conditioning available on each channel. Virtually any kind of passive or active network can be added to each individual channel. There is a ground terminal adjacent to each pair of terminals. The PCI-20025T-2 can be surface-mounted or mounted in a PCI-20029A-1 enclosure (up to four panels per enclosure).

Enclosures

PCI-20029A-1 Enclosure - This card cage accommodates most combinations of analog and digital termination panels in a table-top or rack-mount configuration. The enclosure measures 10.45" (26.5cm) high by 19" (48.3cm) wide by 2.5" (6.4cm) deep and holds up to four PCI-20018T-1, PCI-20024T-2 or PCI-20025T-2 panels.

PCI-20339A-1 Enclosure - This card cage is a rack-mount enclosure measuring 3.5" (8.9cm) high by 19" (48.3cm) wide by 3.7" (9.4cm) deep. It holds one PCI-5B01-1 or one PCI-20048T-1 termination panel.

SIGNAL CONDITIONING / ISOLATOR MODULES

Analog Signal Conditioning Blocks (PCI-5B Series) - The PCI-5B Series is a family of low-cost, high-performance signal conditioning products for analog input/output signals. Each PCI-5B block provides a single channel of isolated analog input or output. The input blocks accept signals from external sources, then filter, isolate, amplify, and convert these signals to high-level analog voltage outputs. Output blocks produce 0 to 20mA or 4 to 20mA current loop signals from voltage inputs for a variety of control applications.

The PCI-5B blocks employ transformer isolation to offer a high level of safety when interfacing computer systems to external equipment processes. The isolation barrier and protection devices prevent damage to expensive control room equipment. Common-mode voltages up to 1500Vrms and up to 240V differential can be safely applied.

Digital Opto-Isolator Blocks (PCI-1100 Series) - The PCI-1100 Series are digital, optically isolated, signal conditioning blocks. A separate opto-block is used for each channel, allowing complete I/O flexibility. The twelve different opto-blocks are divided into two groups: standard and slim-line.

All input models accept both AC and DC voltages and convert them to TTL voltages for input to your data acquisition system. Each

provides a TTL output to drive a standard digital input. Different models are provided for AC and DC outputs. These units convert TTL outputs from the data acquisition system to switch higher voltage (and current) load. The DC output devices present an open collector NPN transistor to the load. The AC output units contain zero crossing circuitry and switch their loads with triacs. All models provide 4000 V isolation input to output.



PCI-1100 Series Blocks

Various combinations of the available opto-blocks can be intermixed on one termination panel. However, each contiguous group of eight channels must contain only input or output opto-blocks. This is because the digital channels on the EDAS-1002E-1 are programmable as inputs or outputs in byte-size (8 channels) units.

PCI-1100 MODEL

Standard/Slimline

Model	Description
PCI-1101/1107	AC/DC input (15-32V), TTL out
PCI-1102/1108	AC/DC input (90-140V), TTL out
PCI-1103/1109	DC output (5 - 60V at 3A), TTL in
PCI-1104/1110	AC output (12-140V at 3A), TTL in
PCI-1105/1111	AC/DC input (180-280V), TTL out
PCI-1106/1112	AC output (24-280V), TTL in

FOR CUSTOM TERMINATION PROJECTS

If you prefer, you can make your own termination panels or custom-length cable to interface to EDAS systems.

For analog termination panels, use a T&B Ansley #609-2627 or equivalent connector. To make custom-length cable, use a T&B Ansley #609-2630 or equivalent connector with standard-density analog cable.

For digital termination panels, use a T&B Ansley #609-3427 or equivalent connector. To make custom-length cable, use a T&B Ansley #609-3430 or equivalent connector with standard-density digital ground-plane cable.

ETHERNET DATA ACQUISITION SYSTEMS

Digital EDAS

- EDAS-1001E-1 EDAS Digital I/O Ethernet Data Acquisition System
- EDAS-1001G-1 EDAS Digital I/O Ethernet Data Acquisition System, board only (OEM version).
- EDAS-1001E-2 EDAS Digital I/O Ethernet Data Acquisition System, with RS-485 serial I/O capability.
- EDAS-1001G-2 EDAS Digital I/O Ethernet Data Acquisition System, board only (OEM version), with RS-485 serial I/O capability.
- EDAS-1001E-SK1 EDAS Starter Kit, Digital I/O, for 90-120VAC power. Includes EDAS, termination panel, Net Link Software Libraries, COM Port Drivers for Windows, DIN-rail mounting kit, power supply, configuration accessories.
- EDAS-1001E-SK2 EDAS Starter Kit, Digital I/O, for 230VAC power. Includes EDAS, termination panel, Net Link Software Libraries, COM Port Drivers for Windows, DIN-rail mounting kit, power supply, configuration accessories.
- EDAS-1027E-1 Industrial Hardened EDAS Digital I/O Ethernet Data Acquisition System
- EDAS-1027E-2 Industrial Hardened EDAS Digital I/O Ethernet Data Acquisition System, with RS-485 I/O

Multifunction EDAS

- EDAS 1031E-1A EDAS 16-bit Multifunction I/O Ethernet Data Acquisition System.
- EDAS 1031E-1AG EDAS 16-bit Multifunction I/O Ethernet Data Acquisition System, board only (OEM version).
- EDAS 1031E-2A EDAS 16-bit Multifunction I/O Ethernet Data Acquisition System, with RS-485 serial I/O capability.
- EDAS 1031E-2AG EDAS 16-bit Multifunction I/O Ethernet Data Acquisition System, board only (OEM version), with RS-485 serial I/O capability.
- EDAS 1031E-SK1 EDAS Starter Kit, 16-bit Multifunction, for 90-120VAC power. Includes EDAS, termination panel, Net Link Software Libraries, COM Port Drivers for Windows, DIN-rail mounting kit, power supply, configuration accessories.
- EDAS 1031E-SK2 EDAS Starter Kit, 16-bit Multifunction, for 230VAC power. Includes EDAS, termination panel, Net Link Software Libraries, COM Port Drivers for Windows, DIN-rail mounting kit, power supply, configuration accessories.
- EDAS-1002E-1A EDAS 12-bit Multifunction I/O Ethernet Data Acquisition System.
- EDAS-1002E-1AG EDAS 12-bit Multifunction I/O Ethernet Data Acquisition System, board only (OEM version).
- EDAS-1002E-2A EDAS 12-bit Multifunction I/O Ethernet Data Acquisition System, with RS-485 serial I/O capability.
- EDAS-1002E-2AG EDAS 12-bit Multifunction I/O Ethernet Data Acquisition System, board only (OEM version), with RS-485 serial I/O capability.
- EDAS-1002E-SK1 EDAS Starter Kit, 12-bit Multifunction, for 90-120VAC power. Includes EDAS, termination panel, Net Link Software Libraries, COM Port Drivers for Windows, DIN-rail mounting kit, power supply, configuration accessories.
- EDAS-1002E-SK2 EDAS Starter Kit, 12-bit Multifunction, for 230VAC power. Includes EDAS, termination panel, Net Link Software Libraries, COM Port Drivers for Windows, DIN-rail mounting kit, power supply, configuration accessories.

Serial EDAS

- EDAS-1025E-1B1 2 port serial EDAS (120 VAC power supply) Net Link Software Libraries, COM Port Drivers for Windows, Hardware Manual and DB9 Null Modem Cable
- EDAS-1025E-1B2 2 port serial EDAS (230 VAC power supply) Net Link Software Libraries, COM Port Drivers for Windows, Hardware Manual and DB9 Null Modem Cable
- EDAS-1025N-1B1 2 port serial EDAS (120 VAC power supply)
- EDAS-1025N-1B2 2 port serial EDAS (230 VAC power supply)
- EDAS-1025G-1B 2 port serial EDAS (OEM version)
- EDAS-1025E-2B1 4 port serial EDAS (120 VAC power supply) Net Link Software Libraries, COM Port Drivers for Windows, Hardware Manual and DB9 Null Modem Cable
- EDAS-1025E-2B2 4 port serial EDAS (230 VAC) Net Link Software Libraries, COM Port Drivers for Windows, Hardware Manual and DB9 Null Modem Cable
- EDAS-1025N-2B1 4 port serial EDAS (120 VAC)
- EDAS-1025N-2B2 4 port serial EDAS (230 VAC)
- EDAS-1025G-2B 4 port serial EDAS (OEM version)

SOFTWARE

EDAS-1006S-1SYSCHECK diagnostic/utility software

iFactory Monitor

EDAS-1033S-1iFactory Monitor Application

Net Link Drivers

EDAS-1003S-4Net Link Software Libraries for Windows 9x/NT/XP/2000

Ethernet/Serial Communications Software

EDAS-1032S-1COM Port Driver for Windows NT/2000

EDAS-1032S-2COM Port Driver for Windows 95/98/ME

TERMINATION & SIGNAL CONDITIONING

Low-Cost Termination Panels

EDAS-1004T-1Digital termination panel for EDAS-1001E systems. No cable required.

PCI-20429T-1Low-cost multifunction termination panel. For EDAS-1002E systems. No cable required.

DIN-Rail Mount Termination Panels

EDAS-1010T-1Analog termination panel, with DIN-rail mounting. Use with 50-pin cables.

EDAS-1011T-1Digital termination panel, with DIN-rail mounting. Use with 34-pin cables.

EDAS-1014A-1DIN-rail mounting tray for termination panels.

3U Termination Panels & Enclosures

PCI-20303T-13U analog I/O panel, 16 SE or 18 diff inputs and 2 outputs

PCI-20303T-23U analog I/O panel, 7 diff inputs, 1 CJC, and 2 outputs

PCI-20353T-13U 5B analog I/O panel, 8 channels

PCI-20354T-13U 5B analog I/O expander panel for the PCI-20353T-1 to increase to 16 channels

PCI-20305T-13U digital I/O panel, 16 channels

PCI-20324T-13U optically isolated digital I/O panel, 8 channels

PCI-20326T-13U optically isolated digital I/O expander panel for the PCI-20324T-1 to increase to 16 channels

PCI-20355T-1Digital relay output panel, 16 channels

PCI-20361T-13U opto-isolated digital input panel, 16 inputs

PCI-20361T-2Quick disconnect version of 3U opto-isolated digital input panel

PCI-20308H-119-inch cage enclosure for 3U-size termination panels

PCI-20348A-1Accessory kit with mounting hardware for up to five 3U-size termination panels

General-Purpose Termination Panels & Enclosures

PCI-5B01-15B analog I/O panel, 16 channels, accepts any 5B signal conditioning blocks

PCI-20024T-2Customizer analog termination panel, up to 32 channels

PCI-20018T-1Isolated digital termination panel, 8 channels*

PCI-20048T-1Isolated digital termination panel, 16 channels*

PCI-20025T-2Customizer digital I/O termination panel, up to 32 channels

PCI-20029A-1Quad termination panel enclosure with cover

PCI-20339A-1Rack mount enclosure for PCI-5B01-1 or PCI-20048T-1

* when used with PCI-1100 Series

Signal Conditioning / Isolator Modules

PCI-5B Series Analog Signal Conditioning Blocks

PCI-1100 Series Digital Opto-Isolator Blocks

ACCESSORIES & ENCLOSURES**Cables**

EDAS-1012A-1 Unshielded cable, 50-pin. Length is 1.5 ft (45.72cm).

EDAS-1012A-2 Unshielded cable, 50-pin. Length is 4 ft (121.92cm).

EDAS-1012A-3 Unshielded cable, 50-pin. Length is 4 in (10.16cm).

EDAS-1012A-5 Unshielded cable, 50-pin. Length is 2 ft (60.96cm).

EDAS-1012A-6 Unshielded cable, 50-pin.; Length is 3 ft (91.44cm).

EDAS-1013A-1 Unshielded cable, 34-pin. Length is 1.5 ft (45.72cm).

EDAS-1013A-2 Unshielded cable, 34-pin. Length is 4 ft (121.92cm).

EDAS-1013A-3 Unshielded cable, 34-pin. Length is 4 in (10.16cm).

EDAS-1013A-5 Unshielded cable, 34-pin. Length is 2 ft (60.96cm).

EDAS-1013A-6 Unshielded cable, 34-pin. Length is 3 ft (91.44cm).

LPA015 Data transfer cable, RS-232 null modem, DE-9 and DB-25.

Manual

EDAS-1009A-1 EDAS manual for EDAS-1001E, EDAS-1002E and EDAS-1031E systems.

EDAS-1030A-1 EDAS manual for EDAS-1025E systems.

Din-Rail Mount Kit

EDAS-1005A-1 DIN-rail mounting kit for EDAS Ethernet data acquisition system. Includes aluminum strap and mounting screws.

EDAS-1014A-1 DIN-rail mounting kit for EDAS-1010T and EDAS-1011T termination panels.

Rack-Mount Kit

EDAS-1028A-1 Rack-mount kit, 19-inch, 1U, for up to 3 EDAS units.

Enclosures

EDAS-1024A-1 Industrial Enclosure, black

EDAS-1024A-2 Industrial Enclosure, grey

Power Supplies

LPP002 24VAC power supply (90-120VAC input) for EDAS data acquisition systems.

LPP003 24VAC power supply (230VAC input) for EDAS data acquisition systems.

Intelligent Instrumentation products are sold and supported in more than 30 countries through a worldwide network of Intelligent Instrumentation Regional Marketing Centers, value added resellers and system integrators. For your convenience, Intelligent Instrumentation maintains an electronic sales and support directory on our web site. To contact the local office nearest you anywhere in the world visit our web site at www.edasce.com.



A TEXAS INSTRUMENTS COMPANY 

Worldwide Headquarters

3000 E Valencia Rd, Suite 100
Tucson, Arizona 85706 USA

Sales and Information:

1-800-685-9911

Fax:

520-573-0522

Technical Support:

520-573-3504

support@edasce.com

Website:

www.edasce.com

E-mail:

sales@edasce.com

U.S. REGIONAL OFFICES: (800) 685-9911

Charlotte, NC

Los Angeles, CA

Minneapolis, MN

Tucson, AZ

International

For the international office nearest you,
contact our worldwide headquarters:

Sales and Information:

520-573-0887

Fax:

520-573-0522

E-mail:

international@edasce.com

Technical Support:

support@edasce.com

International Corporate Offices

France

Sales and Information: (01) 39.54.80.99

Fax: (01) 39.54.69.46

E-mail: france@edasce.com

Website: www.edasce.com/france/

Germany

Sales and Information: 0711-94969-0

Fax: 0711-94969-89

E-mail: mail@instrumentation.de

Website: www.instrumentation.de

Italy

Sales and Information: 015-980096

Fax: 015-980668

E-mail: italy@edasce.com

Website: www.edasce.com/italy/

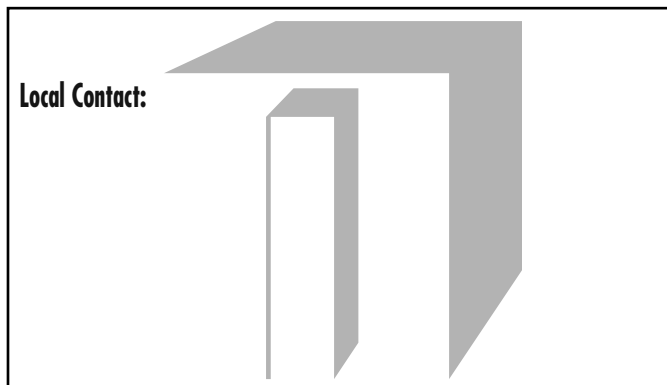

Trademarks EDAS®, EDAS® CE, FactoryView®, LANpoint® CE.NET, LANpoint® PLUS, LANpoint®CE, LANpoint PRO®, FACTORYpoint PRO™, LANpoint Computers®, TIMEpoint®, FACTORYpoint®, DASport®, Intelligent Instrumentation® are trademarks of Intelligent Instrumentation, Inc. Other product and company names listed are trademarks or trade names of their respective companies.

The information provided herein is believed to be reliable; however, INTELLIGENT INSTRUMENTATION assumes no responsibility for inaccuracies or omissions. INTELLIGENT INSTRUMENTATION assumes no responsibility for the use of this information, and all use of such information shall be entirely at the user's own risk. Prices and specifications are subject to change without notice. No patent rights or licenses to any of the circuits described herein are implied or granted to any third party. INTELLIGENT INSTRUMENTATION does not authorize or warrant any INTELLIGENT INSTRUMENTATION products for use in life support or aircraft control applications.